

# LUX Panels

# LUX Panels

LUX panels are Danish design with 40 mm (1.6 in) wide slats. What makes the LUX panels unique is the wrapped veneer on three sides of the slats, giving them an exclusive appearance. The wide slats create a calm and comfortable environment in your home or workplace.

As the veneer is real wood veneer, color variations may occur. The lacquered slats not only provide an exclusive look but also make them easier to clean.

Our LUX panels are aimed at those seeking the elegance of solid wood for their acoustic panel walls. Like our standard acoustic panels, the LUX panel contains a sound-absorbing felt made from PET plastic, which includes up to 50% recycled plastic bottles. This ensures the panel's acoustic functionality and reduces reverberation in your home.

## With our LUX Panels, you get:

### Creative Freedom

LUX panels give you endless possibilities to create your own unique expression and design.

### Exclusive Design

An exclusive appearance, produced with a focus on aesthetics and elegance.

### Danish Craftsmanship

Produced in Central Jutland, ensuring a high standard of quality through Danish design and production.

### The Responsible Choice

After their lifespan, the panels can be recycled, highlighting our commitment to responsible design and environmental awareness.

## Features:

- **Local production**  
All panels are produced in Denmark.
- **Attractive square meter price**  
Competitive price per square meter.
- **Quick assembly**  
Easy and quick installation.
- **Minimal use of tools**  
Requires only a few tools for installation and adjustment.
- **Lightweight construction**  
The panels have a low weight, which simplifies handling.
- **Varied surface options**  
Options for different veneer surfaces and core colors.
- **Veneer oiling**  
Optional purchase of care oils for maintenance and toning of the surface veneer.
- **Environmentally certified materials**  
FSC®-certified MDF and veneer, and CARB2-approved MDF.
- **Cleaning**  
Our panels can easily be cleaned with a wrung-out damp cloth.



These panels are made from FSC™-certified wood and other controlled materials. FSC™ C165957



Sorted as recycled wood.





Oak

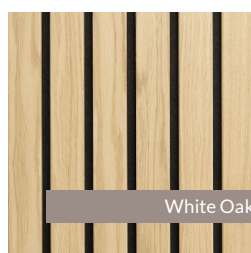

White Oak

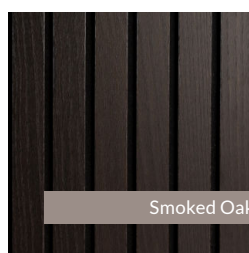

Smoked Oak



















Ash



American Walnut

# Specifications

 Veneer	 Core	 Felt	 Dimensions	 m <sup>2</sup> - f <sup>2</sup>	 Weight
Oak			2400 x 600 x 20 mm - 94.49 x 23.62 x 0.79 in 3000 x 600 x 20 mm - 118.11 x 23.62 x 0.79 in	1,44 - 15.50 1,80 - 19.38	11,4 kg 14,2 kg
White Oak			2400 x 600 x 20 mm - 94.49 x 23.62 x 0.79 in 3000 x 600 x 20 mm - 118.11 x 23.62 x 0.79 in	1,44 - 15.50 1,80 - 19.38	11,4 kg 14,2 kg
Smoked Oak			2400 x 600 x 20 mm - 94.49 x 23.62 x 0.79 in 3000 x 600 x 20 mm - 118.11 x 23.62 x 0.79 in	1,44 - 15.50 1,80 - 19.38	11,4 kg 14,2 kg
Ash			2400 x 600 x 20 mm - 94.49 x 23.62 x 0.79 in 3000 x 600 x 20 mm - 118.11 x 23.62 x 0.79 in	1,44 - 15.50 1,80 - 19.38	11,4 kg 14,2 kg
American Walnut			2400 x 600 x 20 mm - 94.49 x 23.62 x 0.79 in 3000 x 600 x 20 mm - 118.11 x 23.62 x 0.79 in	1,44 - 15.50 1,80 - 19.38	11,4 kg 14,2 kg

## Tolerances

Tolerances: +/- 1mm (0.04 inches). Squareness: Length/width +/- 1mm (0.04 inches). Weight +/- 10%

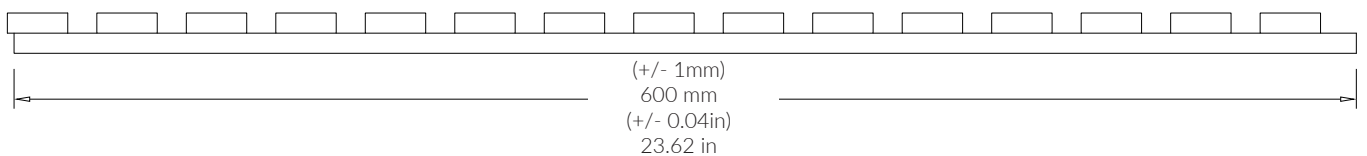
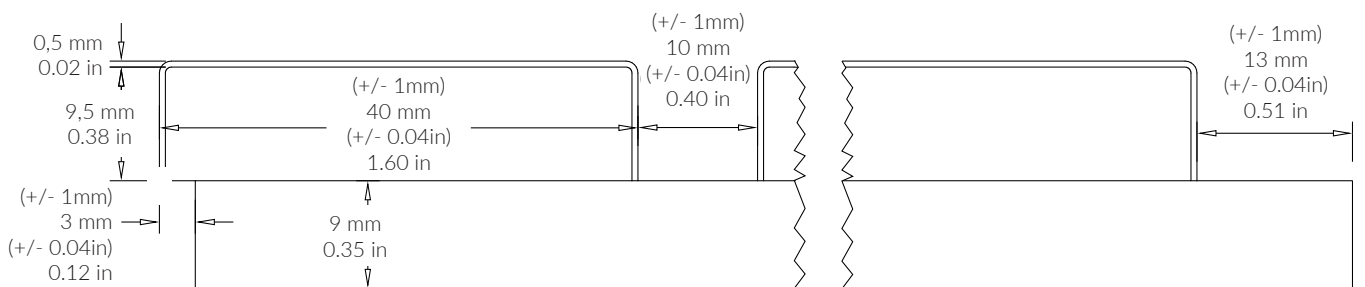
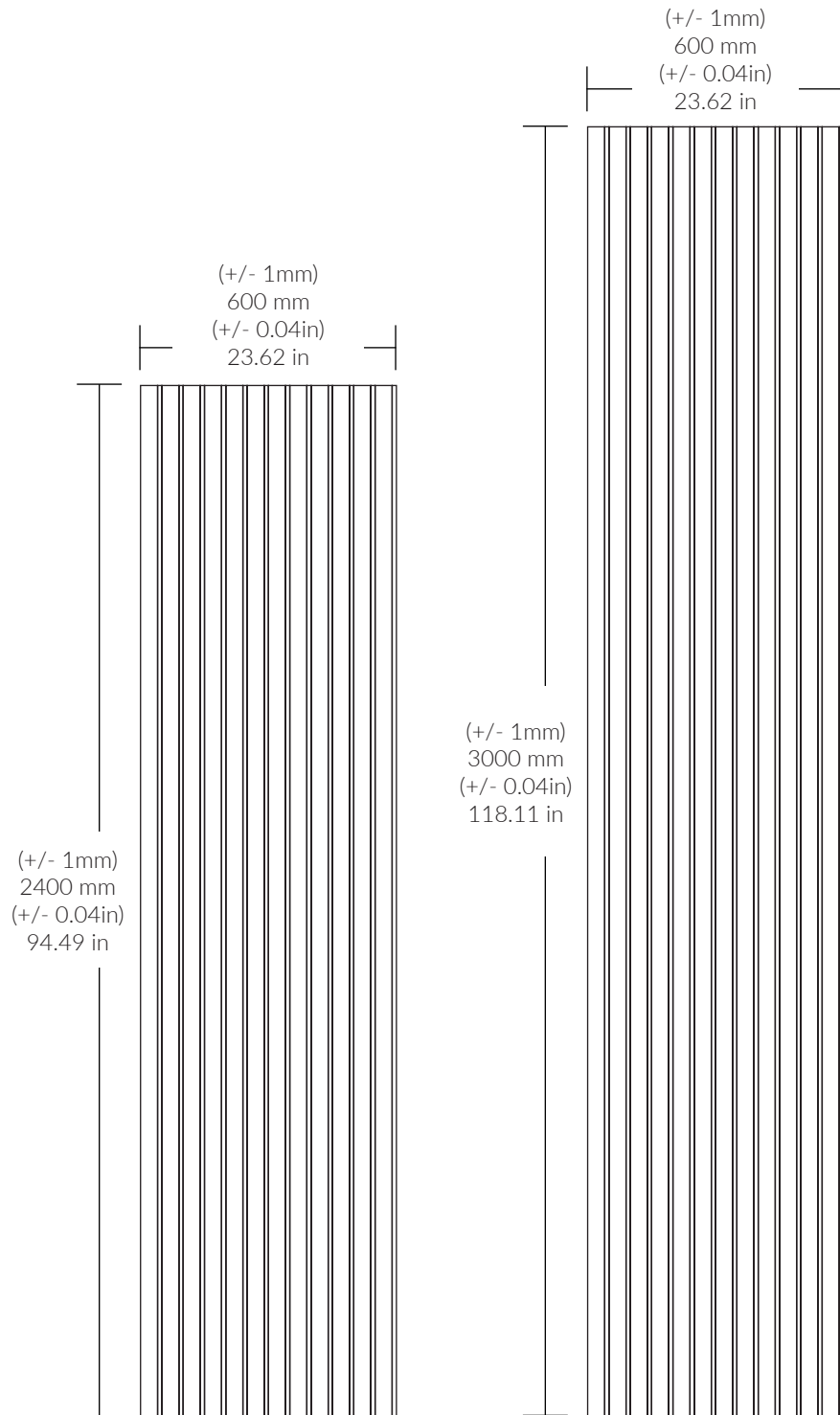

# Acoustic Measurements

Sound test according to DS/EN ISO 354:2003

## Sound test with 45mm air behind the panel

Test area: 10,8 m<sup>2</sup>  
 Room volume: 215 m<sup>3</sup>  
 Room surface area: 305 m<sup>2</sup>

Frequency [Hz]	$\alpha_s$
100	0.09
125	0.22
160	0.30
200	0.53
250	0.56
315	0.87
400	0.99
500	0.97
630	0.97
800	1.02
1k	1.02
1.25k	0.91
1.6k	0.90
2k	0.87
2.5k	0.80
3.15k	0.81
4k	0.77
5k	0.71

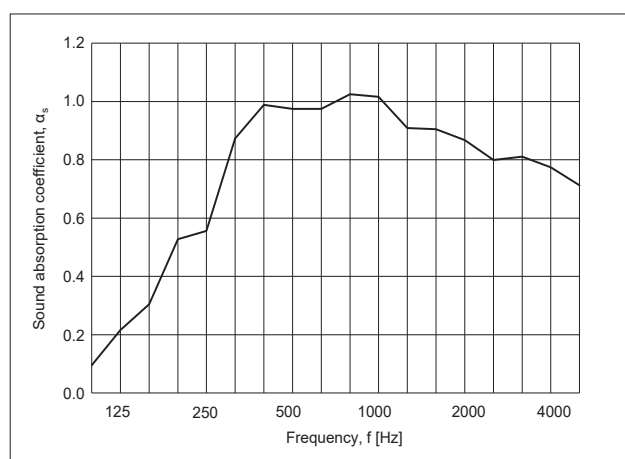

Figure 1: Sound test mounted with 45mm air behind the panel. Closed frame around the edge.

## Sound test with direct wall mounting

Test area: 10,8 m<sup>2</sup>  
 Room volume: 215 m<sup>3</sup>  
 Room surface area: 305 m<sup>2</sup>

Frequency [Hz]	$\alpha_s$
100	0.02
125	0.02
160	0.02
200	0.05
250	0.05
315	0.11
400	0.16
500	0.26
630	0.32
800	0.46
1k	0.63
1.25k	0.78
1.6k	0.97
2k	1.11
2.5k	1.05
3.15k	0.88
4k	0.75
5k	0.68

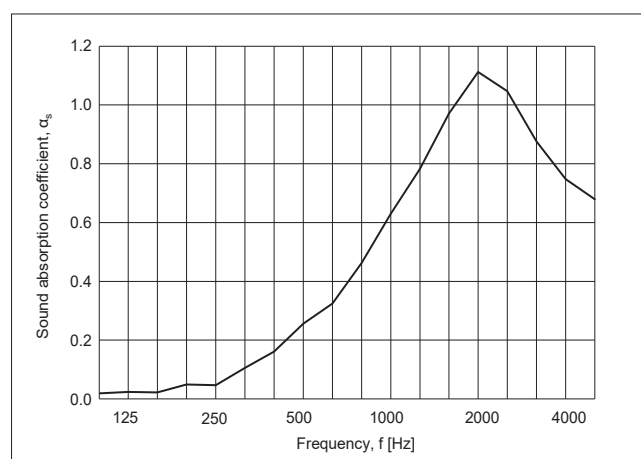
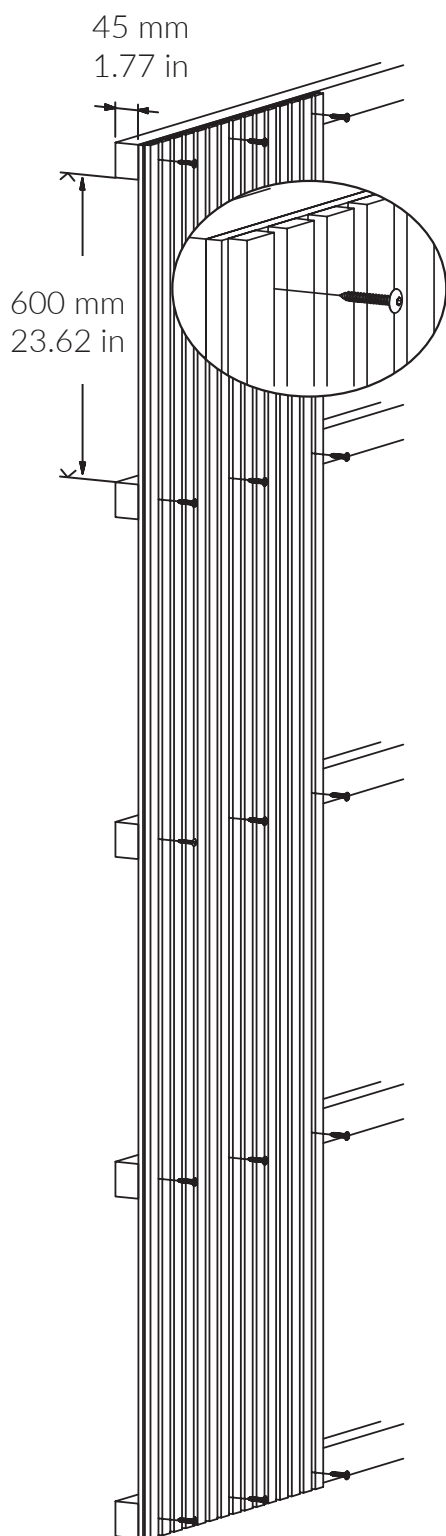

Figure 2: The sound test shows direct wall mounting.

### Tests:

Formaldehyde test: Danish Technological Institute  
 Indoor climate test: Danish Technological Institute  
 Acoustic test: Danish Technological Institute

# Installation Guide



## Method 1

### - Directly on the wall

**Mounting adhesive:** Apply the adhesive to the panel and place it against the wall. Ensure it is firmly pressed.

**Screws:** Screw the panel through the felt and into the wall. We recommend using 4 screws per panel. Remember to use wall plugs if your wall type requires it.

## Method 2

### - On a batten

For optimal sound absorption, set up a batten with 45 mm (1.77 in) battens on your wall. We recommend a spacing of 600 mm (23.62 in) between your battens. Insert mineral wool between the battens. Screw the panel onto the battens through the felt.

#### Panel adaptation:

If you need to customize the panels in width or length, we recommend using a plunge saw or circular saw for cutting.

#### Alternative mounting:

Nail gun diving

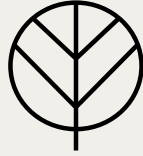

# FOG & VENØ

Fog & Venø is a leading Danish manufacturer of acoustic and decorative panels with and without acoustic properties. These products are designed and manufactured with a focus on Danish craftsmanship and a constant pursuit of high quality.

The panels are suitable for installation on both walls and ceilings.

Fog & Venø has a strategic partnership with world-leading suppliers of materials such as wood veneer, linoleum, foil, and laminate, ensuring that all Fog & Venø products maintain a high standard and a wide range of options. This means that there is constantly reverberation in the room, and this is where our acoustic panels make a big difference.

Our Danish-produced acoustic panels break the sound and absorb the sound wave, so it dies out when it hits the panels. This means that the sound wave is eliminated and the reverberation time is shortened, which will improve the indoor climate and the feeling of well-being in the room, whether it is private, commercial, or public buildings we are talking about.

## Kontaktinformation

Fog & Venø A/S  
Buntmagervej 5, DK-7490 Aulum  
Tel: (+45) 88 77 83 70  
hello@fog-veno.com  
[www.fog-veno.com](http://www.fog-veno.com)