

# Wall Tiles System



# Wall Tiles System

Wall Tiles System is a non-acoustic panel that is ideal for both residential and commercial use. In residential environments, it can be used to give rooms a stylish and modern appearance. In commercial settings such as offices, restaurants, hotels, and retail stores, the panel can be used to create a professional and welcoming atmosphere that impresses customers and guests.

Wall Tiles System is available in a wide range of options. Our genuine wood veneer has natural nuances that add character and create a unique atmosphere in any room. Please note that these nuances may vary.

## **With FOG & VENØ Wall Tiles System, you get:**

### **Creative Freedom**

Wall Tiles System offer endless possibilities to create your own unique expression and design.

### **Exclusive Design**

Our panels are designed with a focus on aesthetics and elegance.

### **Danish Craftsmanship**

Danish design and production ensure a high standard of quality.

### **Environmentally Friendly Materials**

Wall Tiles System with veneer surface is made of FSC®-certified wood.

### **Responsible Choice**

After their lifecycle, the panels can be recycled, underscoring our commitment to responsible design and environmental awareness.

## **Features:**

- **Local production**  
All panels are produced in Denmark.
- **Attractive square meter price**  
Competitive price per square meter.
- **Quick assembly**  
Easy and quick installation.
- **Minimal use of tools**  
Requires only a few tools for installation and adjustment.
- **Lightweight construction**  
The panels have a low weight, which simplifies handling.
- **Varied surface options**  
Options for different veneer surfaces and core colors.
- **Veneer oiling**  
Optional purchase of care oils for maintenance and toning of the surface veneer.
- **Environmentally certified materials**  
FSC®-certified MDF and veneer, and CARB2-approved MDF.
- **Cleaning**  
Our panels can easily be cleaned with a wrung-out damp cloth.



Wood panels are made from FSC™ certified wood and veneer and other controlled materials.  
FSC™ C165957



Sorted as recycled wood.

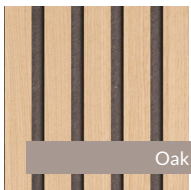

Oak

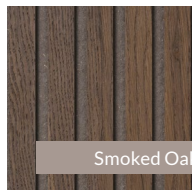

Smoked Oak

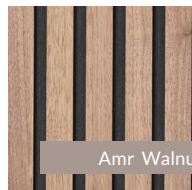

Amr Walnut

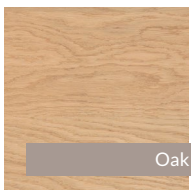

Oak

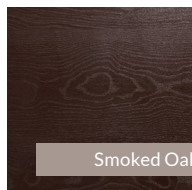

Smoked Oak

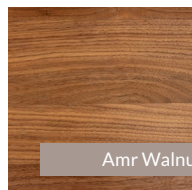

Amr Walnut

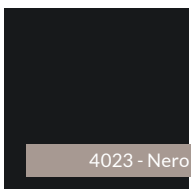

4023 - Nero



4132 - Ash

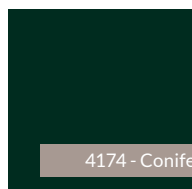

4174 - Conifer

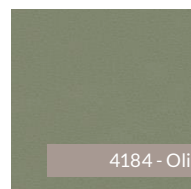

4184 - Olive

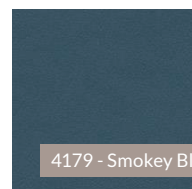

4179 - Smokey Blue

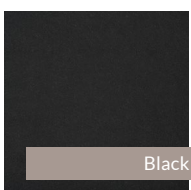

Black

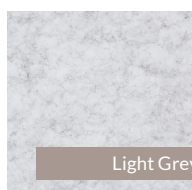

Light Grey

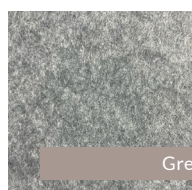

Grey

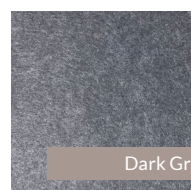

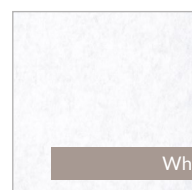

Dark Grey





White

# Specifications

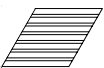
Variant	Veneer - Profiled surface	 Dimensions	 Weight
	Oak	308x267x9,5 mm / 12.1x10.5x0.4 inches	320 g
	Smoked Oak	308x267x9,5 mm / 12.1x10.5x0.4 inches	320 g
	American Walnut	308x267x9,5 mm / 12.1x10.5x0.4 inches	320 g

Variant	Veneer - Profiled surface	Dimensions	Weight
	Oak	459X267x10 mm / 18.1x10.5x0.4 inches	460 g
	Smoked Oak	459X267x10 mm / 18.1x10.5x0.4 inches	460 g
	American Walnut	459X267x10 mm / 18.1x10.5x0.4 inches	460 g

Variant	Veneer - Clean surface	Dimensions	Weight
	Oak	250x217x9,5 mm / 9.8x8.5x0.4 inches 500x433x9,5 mm / 19.7x17x0.4 inches	238 g 952 g
	Smoked Oak	250x217x9,5 mm / 9.8x8.5x0.4 inches 500x433x9,5 mm / 19.7x17x0.4 inches	238 g 952 g
	American Walnut	250x217x9,5 mm / 9.8x8.5x0.4 inches 500x433x9,5 mm / 19.7x17x0.4 inches	238 g 952 g

Variant	Felt	Dimensions	Weight
	Black	250x217x9 mm / 9.8x8.5x0.3 inches 500x433x9 mm / 19.7x17x0.3 inches	69 g 276 g
	Light Grey	250x217x9 mm / 9.8x8.5x0.3 inches 500x433x9 mm / 19.7x17x0.3 inches	69 g 276 g
	Grey	250x217x9 mm / 9.8x8.5x0.3 inches 500x433x9 mm / 19.7x17x0.3 inches	69 g 276 g
	Dark Grey	250x217x9 mm / 9.8x8.5x0.3 inches 500x433x9 mm / 19.7x17x0.3 inches	69 g 276 g
	White	250x217x9 mm / 9.8x8.5x0.3 inches 500x433x9 mm / 19.7x17x0.3 inches	69 g 276 g

Variant	Linoleum - Clean Surface	Dimensions	Weight
	4023 - Nero	250x217x10 mm / 9.8x8.5x0.4 inches 500x433x10 mm / 19.7x17x0.4 inches	274 g 1098 g
	4132 - Ash	250x217x10 mm / 9.8x8.5x0.4 inches 500x433x10 mm / 19.7x17x0.4 inches	274 g 1098 g
	4174 - Conifer	250x217x10 mm / 9.8x8.5x0.4 inches 500x433x10 mm / 19.7x17x0.4 inches	274 g 1098 g
	4184 - Olive	250x217x10 mm / 9.8x8.5x0.4 inches 500x433x10 mm / 19.7x17x0.4 inches	274 g 1098 g
	4179 - Smokey Blue	250x217x10 mm / 9.8x8.5x0.4 inches 500x433x10 mm / 19.7x17x0.4 inches	274 g 1098 g

# Veneer - Profiled surface

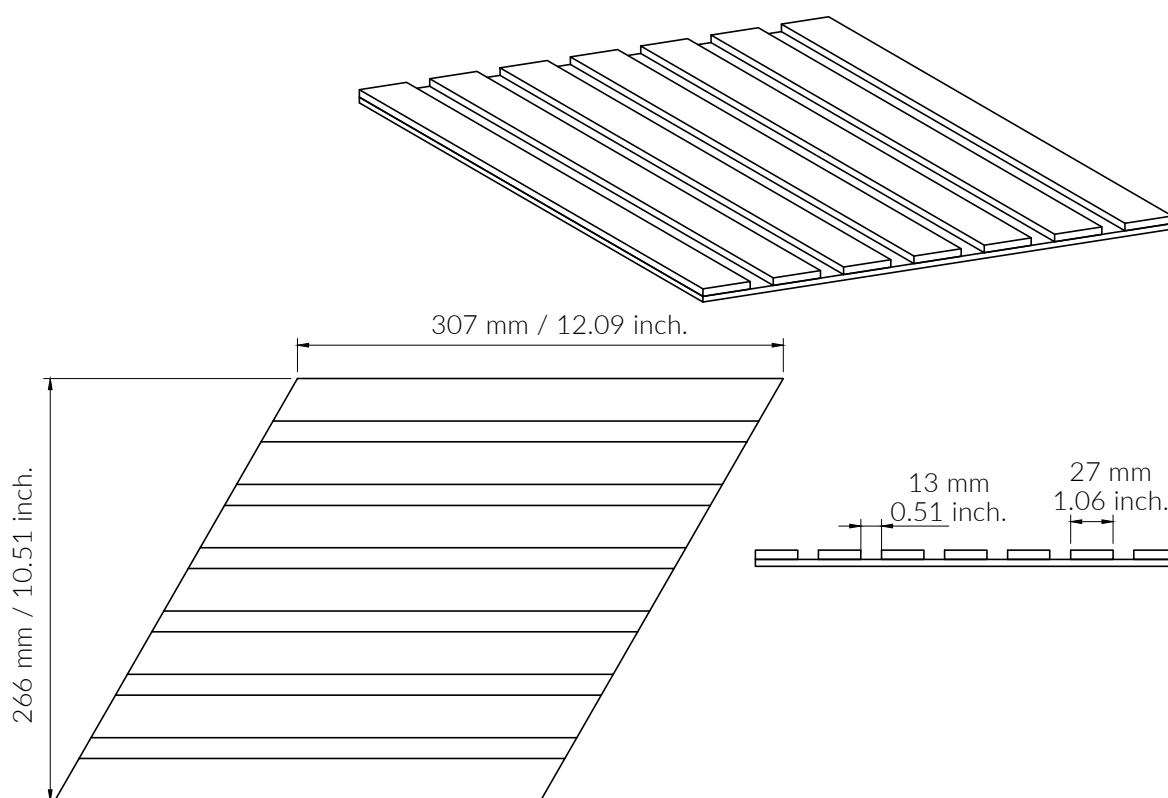
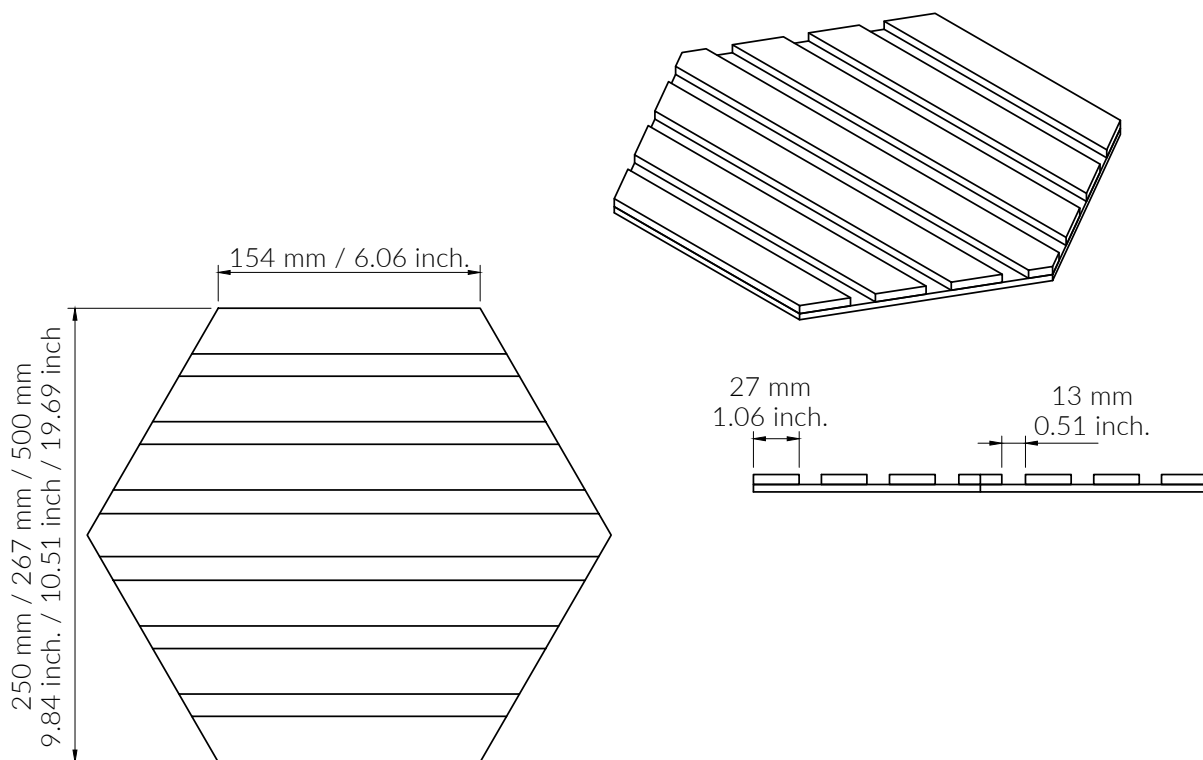

# Veneer/Linoleum/Felt - Clean Surface

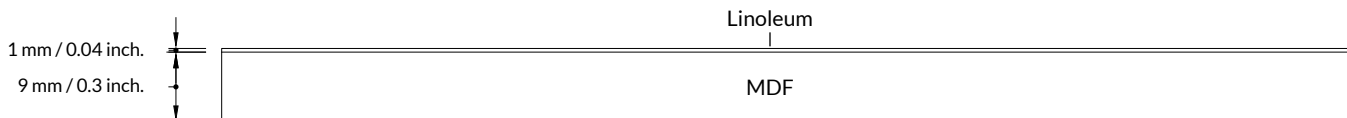
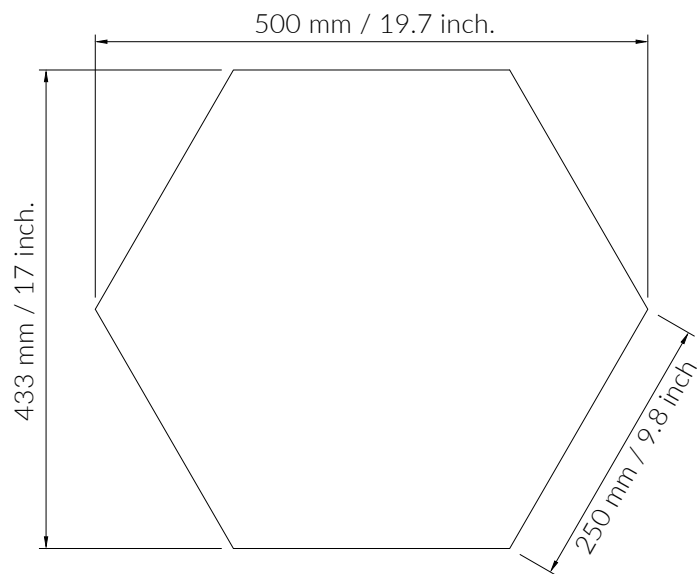
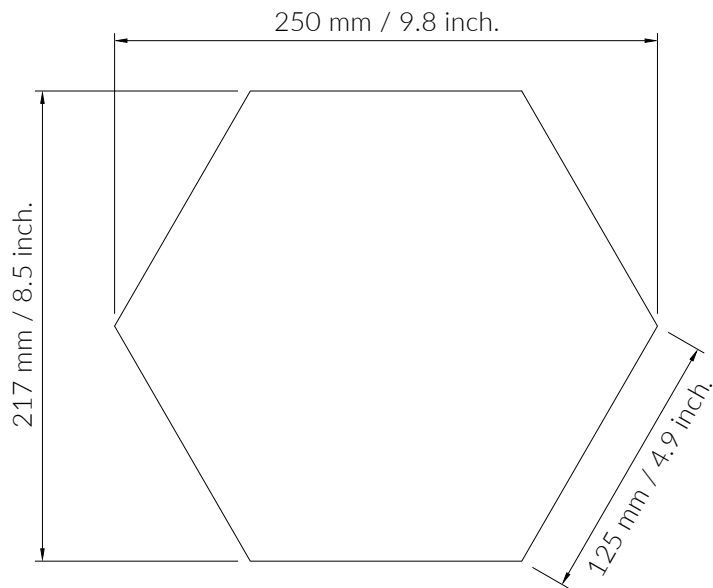



# Installation Guide

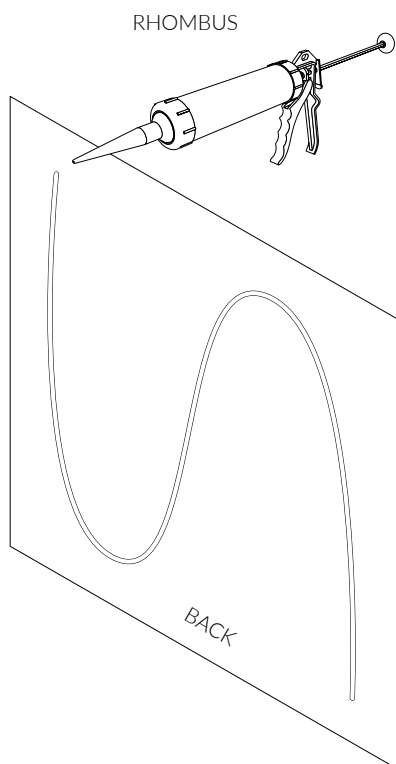
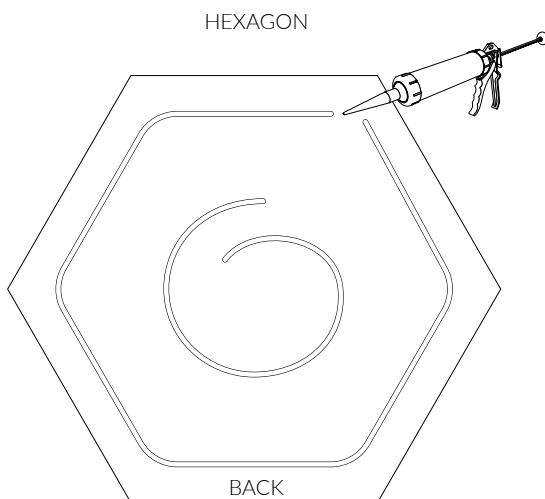

## Installation with Mounting Glue

Fog & Venø recommends the use of mounting glue for Wall Tiles System, to achieve the best results.

### 1. Preparation of the Mounting Area

- Ensure that both the wall and the back of the panel are free from grease and dust. Make sure that the surfaces are dry and that the wall has a suitable surface for good adhesion.

### 2. Application of Mounting Glue

- Evenly distribute the mounting glue across the entire back of the panel.

### 3. Mounting

- Gently press the panel against the wall and hold it in place in the desired position.

### Adjustment of Wall Tiles System:

If you need to adjust Wall Tiles System, we recommend using a plunge saw or circular saw for the cutting.

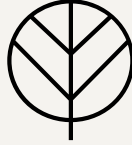

# FOG & VENØ A/S

Fog & Venø is a leading Danish manufacturer of acoustic and decorative panels, with and without acoustic properties. These products are designed and manufactured with a focus on Danish craftsmanship and a constant pursuit of high quality.

The panels are suitable for installation on both walls and ceilings.

Fog & Venø has a strategic partnership with the world's leading suppliers of materials such as wood veneer, linoleum, foil, and laminate, ensuring that all Fog & Venø products maintain a high standard and a wide range of options. This means that there is constant reverberation in the room, and this is where our acoustic panels make a significant difference.

Our Danish-made acoustic panels break the sound and absorb the sound wave, so it dies out when it hits the panels. This means that the sound wave is eliminated and the reverberation time is shortened, which will improve the indoor climate and the feeling of well-being in the room, whether it is private, commercial, or public constructions we are talking about.

## Contactinformation

Fog & Venø A/S  
Buntmagervej 5, DK-7490 Aulum  
Tel: (+45) 88 77 83 70  
hello@fog-veno.com  
[www.fog-veno.com](http://www.fog-veno.com)